

NOVEL APPROACHES FOR THE PRODUCTION OF POLYMER POWDERS FOR SELECTIVE LASER BEAM MELTING OF POLYMERS

J. Schmidt*‡, M. Sachs*‡, S. Fanselow*‡, K.-E. Wirth*‡, W. Peukert*‡

* Institute of Particle Technology, Friedrich-Alexander-Universität Erlangen-Nürnberg, Cauerstraße 4, D-91058
Erlangen, Germany

‡ Collaborative Research Center 814 – Additive Manufacturing, Friedrich-Alexander-Universität Erlangen-
Nürnberg, Am Weichselgarten 6, D-91058 Erlangen, Germany

Abstract

The opening of new fields of application of powder-based additive manufacturing methods like selective laser beam melting of polymers currently is hindered by the limited availability of materials showing good processability. So far, virtually only polyamides are available as optimized powder materials. Two innovative methods for production of spherical polymer micro particles for selective laser melting are discussed: The first approach, stirred media milling and rounding, is applicable for a variety of polymers. It will be exemplarily discussed for polyesters and the dependency of product properties (particle size distribution, shape, crystallinity) on the process parameters in the comminution and in the rounding step will be assessed. The second method, melt emulsification, will be demonstrated for polypropylene. Moreover, the possibilities of dry coating to tailor particle properties are illustrated. The influence of powder properties on the processability and on the quality of the obtained devices is outlined.

Introduction

Additive manufacturing methods allow the tool-free production of complex structures. Especially powder-based generative manufacturing processes like selective laser beam melting (LBM) of polymers seem promising for individualized serial production. With the transition from rapid prototyping to additive manufacturing, i.e. the application of generative manufacturing processes in serial production, the requirements with respect to mechanical part properties as well as process stability and the robustness of the process are constantly rising [1–6]. Besides optimal settings of the process parameters in the LBM process, c.f. for example beam power, beam deflection velocity or building chamber temperature, powders of good flowability and improved bulk density are a prerequisite for obtaining dense parts of proper dimensions [2,4]. Device quality, processability and particle properties are directly connected. Especially the powder flowability is crucial: Powders of good flowability allow for homogeneous powder deposition and frequently show a higher bulk density than powders of inferior flowability, which is advantageous for building of dense devices. Currently the spectrum of commercially available laser sintering powders is quite limited, polyamide (PA) based powder systems have a total market share of approximately 90 % to 95 %, whereby they are made up of mostly of PA 12 and some PA 11 or PA 6. Besides natural PA 12 materials also filled systems (c.f. glass, carbon black) or powders treated with flame retardants are commercialized. Typically the quite expensive (60 to 90 EUR/kg) PA 12 laser sintering powders are produced by emulsion polymerization, suspension polymerization or precipitation processes, i.e. bottom-up approaches. Not only PA powders are commercialized but also systems e.g. based on polystyrene (PS), polypropylene (PP) thermoplastic elastomers (TPE) or poly ether etherketone (PEEK) are available [2,4,5]. Polymer powders produced by cryogenic dry grinding [7] are available, too, however, they often show poor processability due to the bad flowability of the typical irregular shaped particles obtained by comminution processes [8].

Two innovative methods that allow for the production of spherically shaped particles for additive manufacturing are discussed (see Figure 1): In the first approach, powders of good flowability are produced by a process chain consisting of wet grinding [8] with subsequent rounding of the irregular particles in a heated downer reactor [9] and dry coating [10]. Both, the change of the particle shape (rounding) and the increase of surface roughness by dry coating improve the powder flowability. The second approach, melt emulsification of

polymers [11], allows to produce spherical particles in a single process step. To further improve flowability of particles obtained by melt emulsification dry coating may be applied as well. Within this contribution, the effect of particle shape and surface functionalization on bulk density, tensile strength of powders and powder deposition behavior will be outlined exemplarily for polybutylene terephthalate materials. Melt emulsification will be exemplified for polypropylene.

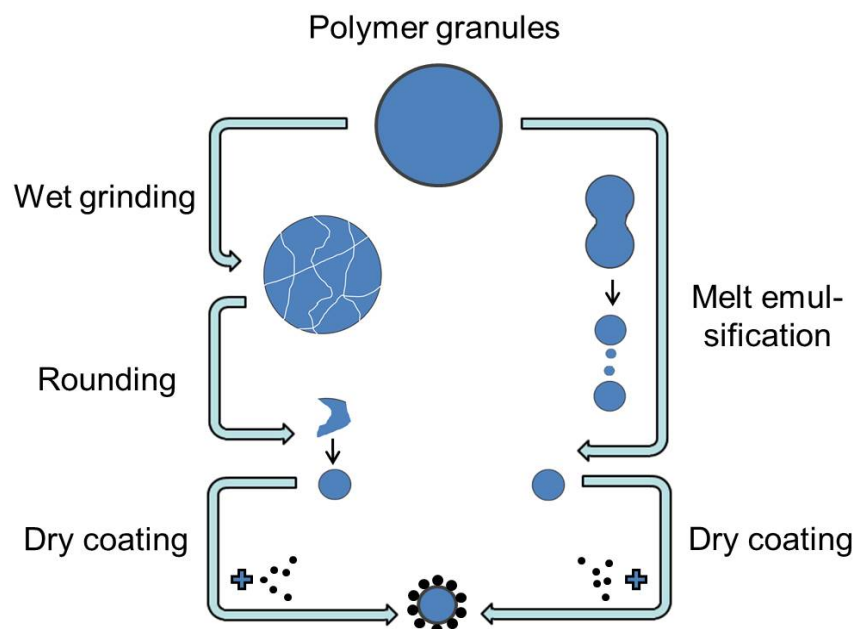

Figure 1: Novel methods for the production of spherical polymer microparticles for laser beam melting. left: comminution of polymers followed by particle rounding in a heated downer reactor; right: melt emulsification. Dry coating of the obtained spherical particles further improves powder flowability.

Materials and methods

Materials

For the process chain approach, i.e. grinding of the polymer followed by rounding and dry coating, PBT 4520 Ultradur Highspeed (BASF) granules have been applied as raw material. The millimeter-sized PBT granules have been pre-cooled with liquid nitrogen and subsequently impact-comminuted with a rotary impact mill Pulverisette-14 (Fritsch) operated at $20,000 \text{ min}^{-1}$ and equipped with a 0.5 mm sieve ring. A coarse PBT powder ($x_{50,3} = 239 \text{ }\mu\text{m}$) was obtained which has been used as feed material for wet grinding. For wet comminution denatured ethanol (95 %, VWR) was used as solvent. The second approach, melt emulsification, was performed with polypropylene PP 520P (Sabic). Hexadecane (Alfa Aesar) was applied as continuous phase. Sodium dioctyl sulfosuccinate (AOT; Acros Organics) was the emulsifier and stabilizer. Fumed silica (Evonik Industries) with a primary particle size of about 7 nm has been applied for dry coating of the rounded PBT and the PP powders.

Methods

Laser diffraction particle sizing

Particle size distributions of the product particles were determined by laser diffraction particle sizing using a Mastersizer 2000 (Malvern) equipped with a Hydro 2000S wet dispersion unit. To obtain stable dispersions appropriate stabilization has been assured (for details see [9,11]).

Scanning electron microscopy

The product particles have been characterized by scanning electron microscopy (SEM). A Gemini Ultra 55 (Zeiss) device equipped with a through-the-hole detector was used at an acceleration voltage of 1 to 1.2 kV.

Tensile strength of powders

Flowability of the products was assessed by measuring the tensile strength of the powders using a tensile strength tester. For details on the procedure please refer to [9,12,13]. In the experiments, a load of 153 Pa was applied.

Powder deposition behavior (model experiment)

The powder deposition behavior of the PBT powders was assessed by doctor blading using a Quadruple Film Applicator Model 360 (Erichsen). The gap size was 120 μm . As substrate, a black-colored paper was used and the area covered with powder was determined with the image analysis software "Image J". The coverage with powder allows to assess the processability of the material in the LBM process during the deposition step. For further details please refer to [10].

Experimental setup

Wet comminution

Wet comminution of PBT has been performed in the batch stirred media mill PE5 (Netzsch). A three-disc stirrer (stirrer discs made of polyethylene) was used and the grinding chamber was lined with silicon nitride ceramics. A mass fraction of about 18.5 % feed material was applied, the solvent was ethanol. A stress energy SE [14] of 1.9 mJ was chosen by using grinding media made of Yttria-stabilized zirconia (YTZ, density ρ_{GM} : 6,050 kg m^{-3}) of 2.0 mm diameter (d_{GM}) and operating the mill at a stirrer tip speed of $v_{\text{tip}} = 6.3 \text{ m s}^{-1}$ corresponding to a stirrer rotational frequency of 800 min^{-1} . The maximum energy SE that may be transferred to a product particle in a stirred media mill is proportional to the kinetic energy of the grinding media ($\text{SE} \propto \rho_{\text{GM}} \cdot d_{\text{GM}}^3 \cdot v_{\text{tip}}^2$). About 14.5 kg grinding beads were filled into the grinding chamber. The process temperature was (20 +/- 2) °C. The irregular shaped PBT particles were separated from the solvent by centrifugation and dried prior to rounding.

Rounding

Rounding was performed in a heated downer reactor equipped with a nine stage heating system (Thermal Technology), where the particles are molten, rounded and solidified. The process is described in great detail in [9]. Nitrogen (purity 5.0, Linde) was used as inert carrier gas. For powder dispersion and aerosol generation a PALAS RGB 1000 powder disperser with brush was used. The aerosol enters the heated downer reactor in the center of its cross section and is surrounded by sheath gas (N_2) to minimize the contact between particles and the reactor wall. Further details on the reactor setup as well as the rounding process and the selection of proper process parameters (temperature profile, residence time) can be found elsewhere [9]. With respect to process temperature the reactor can be divided into three zones starting from the aerosol inlet at the top: In the first zone total gas flow is gradually heated to the process temperature necessary for rounding of PBT (> 230 °C). In the second zone a constant temperature above the polymer's melting temperature is applied to complete the rounding process. In the third zone the temperature is gradually decreased and the solidification occurs. The solid particles are separated at the bottom of the reactor from the carrier gas.

Dry coating

The dry particle coating process was accomplished in a tumbling mixer T2F (Bachofen). The polymer host particles were mixed with fumed silica guest particles (0.1 wt.-%) at 72 min^{-1} for approximately 10 minutes. Details on dry coating of polymers and its influence on flowability may be found in our previous work [9,10].

Melt emulsification

A scheme of the melt emulsifier used is depicted in Figure 2. All pipes and the stirred tank 'B-1' are double-walled and can be heated with heat-transfer oil. The stirred tank 'B-2' is double-walled as well and may be water-cooled. Firstly, the continuous phase, the stabilizer and the polymer granules were introduced into the stirred tank 'B-1' and the whole device was flushed and pressurized with nitrogen (purity 5.0, Linde) as inert gas. Then the device was heated above the melting temperature of the polymer and a pre-emulsion was formed using the stirrer in tank 'B-1'. The hot pre-emulsion was fed by a gear pump into the rotor-stator device where the fine emulsion is formed by intensive shear and elongational stress. Finally, the emulsion is transferred (directly or via a heat exchanger) into the (cooled) stirred tank 'B-2'. After setting the pressure of the device to ambient conditions the polymer particle suspension may be collected by opening the bottom valve of the stirred tank 'B-2'. The polymer particles were separated from the liquid phase by centrifugation, washed and dried. For more details please refer to [11].

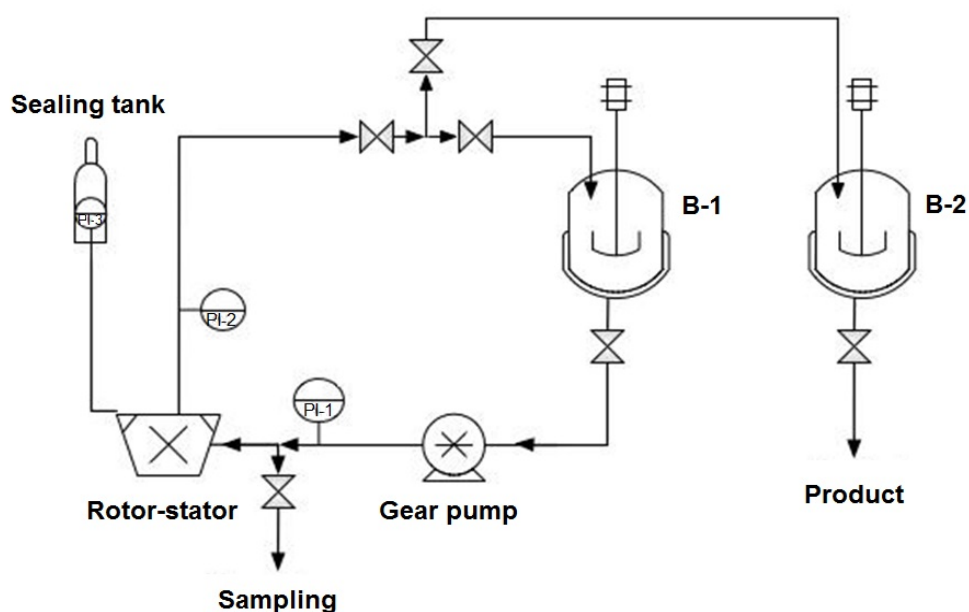

Figure 2: Simplified scheme of the melt emulsification plant.

Results and discussion

Process chain for spherical PBT particles

It has been demonstrated that wet grinding of polymers [8,15] is advantageous compared to (cryogenic) dry grinding processes typically employed for the comminution of plastic or viscoelastic matter [7,16–18] with respect to product particles. Moreover, no intensive cooling is necessary and the process is not limited to brittle polymers like e.g. polystyrene. Polymers with rather high breakage elongation like polyesters may be processed as well. For PBT product particles of size $x_{50,3} = 25.2 \mu\text{m}$ were obtained after around 6 hours of wet comminution under the conditions given above in the section 'Experimental setup'. The particle size distribution of the PBT comminution product was rather broad, a span $(x_{90,3} - x_{10,3}) / x_{50,3}$ of 10.7 was observed. The product particles were separated from the solvent by centrifugation and dried.

After rounding of the comminution product in the heated downer reactor almost perfect spherical particles (see Figure 3) of size $x_{50,3} = 18.8 \mu\text{m}$ are obtained. A smaller particle size of the

rounded particles compared to the grinding product is due to some classification in the downer reactor and due to the changes in particle shape. A slight change in crystallinity from 36 % for the comminution product to 32 % for the rounded product has been found. The degree of crystallinity was determined by dynamic scanning calorimetry assuming a heat of fusion of 145.5 J/g for fully-crystalline α -PBT. The residence time of the particles at a temperature > 230 °C chosen was 7.7 s which allows for complete rounding: Under the experimental conditions one can assume laminar flow and no back-mixing of particles and gas [19] for the calculation of the aforementioned residence time. It has been shown [9] that the minimum residence time for complete rounding can be estimated by the sintering time to form a fully coalesced sphere from particle aggregates applying a viscous flow-sintering model [20].

Equation 1
$$t = \frac{4.20 \cdot \eta \cdot a_f}{\sigma}$$

Equation 1 represents a solution obtained by the aforementioned sintering model. The structure of the initial aggregate does not affect the necessary sintering time t needed to obtain a fully coalesced sphere. The sintering time t is a function of the polymer melt viscosity η , the surface tension σ and the final radius of the aggregate formed, a_f . For typical material parameters of PBT ($\sigma = 30.2$ mNm⁻¹ [21], $\eta = 452$ Pas [22]) a characteristic sintering time of about 1.5 s is calculated for particles of radius $a_f = 0.5 \cdot x_{90,3}$ (rounded PBT) = 22.9 μ m. The change of the particle shape (rounding) improves remarkably the flowability of the PBT particles (see below).

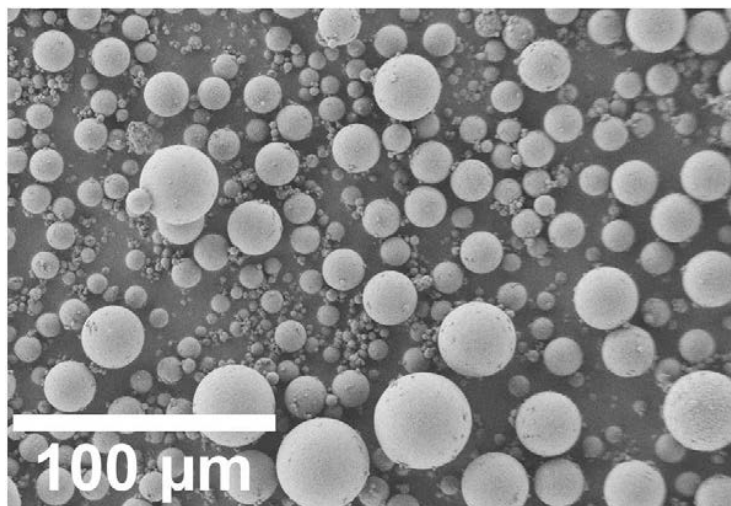

Figure 3: Spherical PBT particles of good flowability obtained by wet comminution and subsequent rounding in a heated downer reactor and dry coating.

A further improvement of flowability is realized by dry particle coating [23–25] of the rounded PBT particles using fumed silica (see section ‘Experimental setup’ for conditions). By the attachment of silica nanoparticles the surface roughness is increased leading to a decrease of the adhesion force between the particles [26,27]. Consequently, the powder flowability increases, which is advantageous for the deposition step in laser beam melting of polymers.

Melt emulsification of PP

The advantage of the melt emulsification as compared to the process chain approach is that it allows the production of spherical polymer microparticles in a single process step if appropriate conditions for processing

are found. Especially finding stable conditions and emulsifying polymers of high melt viscosity are a challenge. The size of the product particles is not only determined by the stressing conditions that apply (c.f. shear rate), i.e. ‘breakage of melt droplets’, but also by the stability of the emulsion, i.e. amongst others by coalescence phenomena which are a function of droplet concentration, emulsifier type and concentration and temperature. PP could successfully be melt-emulsified in a hexadecane–AOT system with a dispersed phase concentration of 5 wt.-% at a process temperature of 190°C. The process is discussed in great detail in [11]. After a process time of 30 minutes particles of a size $x_{50,3} = 22.1 \mu\text{m}$ were obtained. In the case of PP the continuous hexadecane phase acts as plasticizer and allows for reduction of the melt viscosity to around $\eta \approx 1 \text{ Pas}$ (at 190 °C) which facilitates the emulsification process. The product particles were transferred to a n-hexane phase and spray-dried. A fine particle fraction ($x_{50,3} = 17.2 \mu\text{m}$) and coarse material ($x_{50,3} = 29.8 \mu\text{m}$) were collected and the powders were coated with fumed silica as flowing agent. The powders could be successfully applied to produce thin layer specimen in LBM [11].

Tensile strength, bulk density and powder deposition of polymer powders

The effect of change of particle shape (rounding) and increase of surface roughness (dry coating) on the flowability of the powders has been studied using a tensile strength tester. In short, the device allows to assess interparticulate forces by measurement of the force needed to separate two adjacent layers of particles. The measured tensile strength allows for predictions of powder flowability: with decreasing tensile strength, the flowability increases. Moreover, the measurement is done for almost uncompacted powders, which is quite close to the conditions that apply for the powder deposition step in LBM. Tensile strengths of PBT powders obtained after the single process steps and data on the powders’ bulk densities are given in Table 1. Table 2 summarizes the tensile strength of coarse PP powder produced by melt emulsification.

	tensile strength / Pa	bulk density / g/cm ³
wet comminuted PBT	15.7 +/- 0.8	0.25
rounded PBT	10.7 +/-1.7	0.47
rounded & dry coated PBT	2.9 +/- 0.6	

Table 1: Tensile strength and bulk density of the PBT powders(produced by process chain).

	tensile strength / Pa
coarse PP ($x_{50,3} = 29.8 \mu\text{m}$)	9.1 +/- 1.2
dry coated coarse PP ($x_{50,3} = 29.8 \mu\text{m}$)	1.8 +/- 0.2

Table 2: Tensile strength of melt-emulsified PP particles.

Obviously rounding and dry coating lead to a decrease of the powder tensile strength (improvement of powder flowability) by a factor of more than 5 as compared to the comminution product. The tensile strength of 2 to 3 Pa for the dry coated PBT and PP powders is close to that measured for commercial PA12 laser sintering powder. Moreover, by rounding of PBT the packing density of the powder is roughly doubled. The effects of particle shape and particle surface roughness are reflected by the powder deposition behavior studied in the model experiment for PBT (Figure 4) as well: For wet comminuted PBT an area coverage of (19.1 +/- 4.2) % was observed, whereas an almost complete surface coverage of (97.3 +/- 1.8) % is achieved for rounded & dry coated PBT. Small tensile strength of powders (good flowability) correlates with homogeneous powder deposition and almost complete surface area coverage.

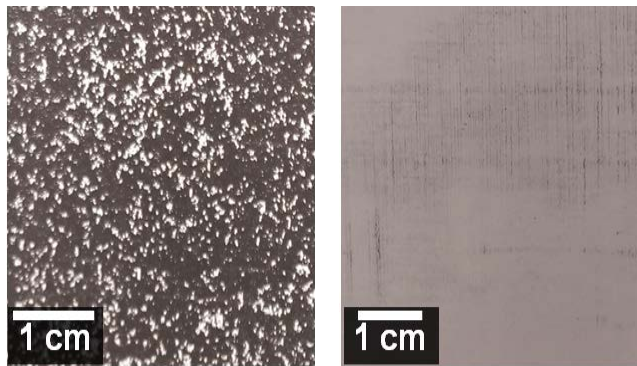

Figure 4: Powder deposition behavior of ground PBT (left) and rounded & dry coated PBT (right) after doctor blading.

Conclusions

Two novel approaches [9,11] to produce spherical polymer microparticles of good flowability have been addressed in this contribution: a process chain consisting of a wet comminution step followed by rounding of the grinding product and dry coating has been exemplified for PBT, the second approach, melt emulsification with subsequent dry coating for PP. Powders of good flowability are the prerequisite to obtain dense parts in LBM[10,28]. Both approaches allow for powders of very good flowability and may be applied to a variety of polymers. Moreover, the processes are scalable, i.e. might be transferred to the plant scale, which makes them interesting for production of LBM powders.

Acknowledgements

German Research Foundation (DFG) is acknowledged for funding our studies in the framework of CRC 814 ‘Additive Manufacturing’ (subprojects A1, A2, A3).

References

- [1] J.P. Kruth, X. Wang, T. Laoui, L. Froyen, Lasers and materials in selective laser sintering, *Assembly Automation* 23 (2003) 357–371.
- [2] R.D. Goodridge, C.J. Tuck, R. Hague, Laser sintering of polyamides and other polymers, *Progress in Materials Science* 57 (2012) 229–267.
- [3] A. Gebhardt, *Generative Fertigungsverfahren: Additive manufacturing und 3D-Drucken für Prototyping - Tooling - Produktion*, 4th ed., Hanser, München, 2013.
- [4] T.T. Wohlers, *Wohlers report 2014: 3D printing and additive manufacturing state of the industry annual worldwide progress report*, Wohlers Associates, Fort Collins, Col., 2014.
- [5] M. Schmid, *Selektives Lasersintern (SLS) mit Kunststoffen: Technologie, Prozesse und Werkstoffe*, Hanser, München, 2015.
- [6] G. Witt, *Neue Entwicklungen in der Additiven Fertigung*, Springer Berlin Heidelberg, 2016.
- [7] M. Wilczek, J. Bertling, D. Hintemann, Optimised technologies for cryogenic grinding, *International Journal of Mineral Processing* 74 (2004) S425-S434.
- [8] J. Schmidt, M. Plata, S. Tröger, W. Peukert, Production of polymer particles below 5 μm by wet grinding, *Powder Technology* 228 (2012) 84–90.
- [9] J. Schmidt, M. Sachs, C. Blümel, B. Winzer, F. Toni, K.-E. Wirth, W. Peukert, A novel process route for the production of spherical LBM polymer powders with small size and good flowability, *Powder Technology* 261 (2014) 78–86.
- [10] C. Blümel, M. Sachs, T. Laumer, B. Winzer, J. Schmidt, M. Schmidt, W. Peukert, K.-E. Wirth, Increasing flowability and bulk density of PE-HD powders by a dry particle coating process and impact on LBM processes: null: *Rapid Prototyping Journal*, *Rapid Prototyping Journal* 21 (2015) 697–704.

- [11] S. Fanselow, S.E. Emamjomeh, K.-E. Wirth, J. Schmidt, W. Peukert, Production of spherical wax and polyolefin microparticles by melt emulsification for additive manufacturing, *Chemical Engineering Science* 141 (2016) 282–292.
- [12] A. Schweiger, I. Zimmermann, A new approach for the measurement of the tensile strength of powders, *Powder Technology* 101 (1999) 7–15.
- [13] K. Meyer, I. Zimmermann, Effect of glidants in binary powder mixtures, *Powder Technology* 139 (2004) 40–54.
- [14] A. Kwade, Determination of the most important grinding mechanism in stirred media mills by calculating stress intensity and stress number, *Powder Technology* 105 (1999) 382–388.
- [15] M. Wolff, S. Antonyuk, S. Heinrich, G.A. Schneider, Attritor-milling of poly(amide imide) suspensions, *Particuology* 17 (2014) 92–96.
- [16] D. Landwehr, M.H. Pahl, Kaltzerkleinerung von Gewürzen, *Chemie Ingenieur Technik* 58 (1986) 246–247.
- [17] M. Juhnke, R. Weichert, Zerkleinerung weicher Materialien ohne Verunreinigung der Produkte durch die Mahlkörper, *Chemie Ingenieur Technik* 77 (2005) 90–94.
- [18] A. Weber, U. Teipel, H. Nirschl, Comparison of Comminution by Impact of Particle Collectives and Other Grinding Processes, *Chem. Eng. Technol.* 29 (2006) 642–648.
- [19] H. Brust, K.-E. Wirth, Residence Time Behavior of Gas in a Downer Reactor, *Ind. Eng. Chem. Res.* 43 (2004) 5796–5801.
- [20] M.J. Kirchhof, H.-J.Schmid, W. Peukert, Three-dimensional simulation of viscous-flow agglomerate sintering, *Physical review.E, Statistical, nonlinear, and soft matter physics* 80 (2009) 26319.
- [21] E.N. Ito, M.M. Ueki, R.E.S. Bretas, E. Hage Junior, Interfacial tension of PBT/SAN blends by the drop retraction method, *Mat. Res.* 11 (2008) 165–169.
- [22] S. Fakirov (Ed.), *Handbook of Thermoplastic Polyesters*, Wiley-VCH Verlag GmbH & Co. KGaA, Weinheim, FRG, 2002.
- [23] H. Rumpf, Die Wissenschaft des Agglomerierens, *Chemie Ing. Techn.* 46 (1974) 1–11.
- [24] R. Pfeffer, R.N. Dave, D. Wei, M. Ramlakhan, Synthesis of engineered particulates with tailored properties using dry particle coating, *Powder Technology* 117 (2001) 40–67.
- [25] J. Yang, A. Sliva, A. Banerjee, R.N. Dave, R. Pfeffer, Dry particle coating for improving the flowability of cohesive powders, *Powder Technology* 158 (2005) 21–33.
- [26] H. Zhou, M. Götzinger, W. Peukert, The influence of particle charge and roughness on particle–substrate adhesion, *Powder Technology* 135-136 (2003) 82–91.
- [27] M. Götzinger, W. Peukert, Particle Adhesion Force Distributions on Rough Surfaces, *Langmuir* 20 (2004) 5298–5303.
- [28] S. Ziegelmeier, P. Christou, F. Wöllecke, C. Tuck, R. Goodridge, R. Hague, E. Krampe, E. Wintermantel, An experimental study into the effects of bulk and flow behaviour of laser sintering polymer powders on resulting part properties, *Journal of Materials Processing Technology* 215 (2015) 239–250.